

---

# Senior Colloquium: *History of Mathematics*

Math 400 Spring 2020

Fowler 310 T 1:30pm - 2:55pm

© 2020 Ron Buckmire

<http://sites.oxy.edu/ron/math/400/20/>

---

## Worksheet 3: Tuesday February 11

**TITLE** Other 18<sup>th</sup> Century Mathematicians: Agnesi, Bernoulli, Clairaut, D'Alembert, Lagrange, Laplace and Legendre

**CURRENT READING** Katz, 611-636; Boyer 390-396, 423-427, 430-433, 443-450.

**NEXT READING** Katz, 712, 819-822, 834-838; Boyer 464-476;

---

By the end of the 18<sup>th</sup> century mathematicians were beginning to feel that mathematics was “exhausted” (Struik, 136). Francois Arago wrote in 1842's *Éloge de Laplace* (Eulogy for Laplace):

**Five geometers—Clairaut, Euler, d'Alembert, Lagrange, and Laplace—shared between them the world of which Newton had revealed the existence. They explored it in all directions, penetrated into regions believed inaccessible, pointed out countless phenomena in those regions which observation had not yet detected, and finally—and herein lies their imperishable glory—they brought within the domain of a single principle, a unique law, all that is most subtle and mysterious in the motions of the celestial bodies.**

### Alexis-Claude Clairaut (1713-1765)

Clairaut was born and died in Paris. He is most well-known for his work in differential equations. He was a child prodigy who published his first paper at age 12 and was elected to the Paris Academy of Sciences at age 18. He is also known for going on an expedition which confirmed a result of Newton and Huygens that the Earth would be flattened (less spherical) at the poles that was published in his *Théorie de la figure de la Terre* (A theory on the shape of the Earth).

### Joseph Louis Lagrange (1736-1813)

Lagrange was born in Turin, Italy and Boyer ranks him as the second greatest mathematician of the 18<sup>th</sup> century (behind Euler). When Euler left Berlin for St. Petersburg, Lagrange took the position the Swiss great had vacated. Lagrange is most well-known for trying to come up with a more analytically rigorous foundation for the calculus, and in 1797 he published *Théorie des fonctions analytique contenant les principes du calcul differential* (*Theory of analytic functions containing the principles of differential calculus*). In his masterwork of 1787, *Mécanique analytique* (*Analytic Mechanics*) he gave the general equations of motion of a dynamical system that are today known as Lagrange's Equations. In the preface of this book, Lagrange wrote “*On ne trouvera point de figures dans cet ouvrage, seulement des opérations algébriques*” (*One will not find figures in this work, only algebraic operations*). This was done to dramatically separate this work from the classic geometric texts of the Greeks and confirm the modern supremacy of algebra and analysis.

### Jean le Rond D'Alembert (1717-1783)

D'Alembert was named for the church, Saint-Jean-le-Rond-de-Paris, he was found outside of as an infant, abandoned by his mother due to his illegitimate status. D'Alembert was a rival of Clairaut's and was admitted to the French Academy of Sciences at the ripe old age of 24. D'Alembert is most well-known for his proof of the Fundamental Theorem of Algebra (which in France is known as the d'Alembert-Gauss Theorem) as well as his 1743 book *Traite de dynamique* (Treatise on dynamics) in which he derives and proposes a solution for one of the three fundamental partial differential

equations of mathematical physics, the wave equation  $\frac{\partial^2 u}{\partial x^2} = \frac{\partial^2 u}{\partial t^2}$ . D'Alembert became the permanent secretary of the

French Academy and contributed greatly to the publication of *Encyclopédie*, the huge encyclopedic publication of the French Academy that attempted to compile all the knowledge of the Enlightenment.

**Pierre-Simon Laplace** (1749-1827)

Laplace was a contemporary of the others but didn't publish until the turn of the 19<sup>th</sup> century. His *Traité de mécanique céleste* (*Treatise on Celestial Mechanics*) earned him the sobriquet “the Newton of France” and was a 5-volume compendium of all discoveries in this field to date. Laplace is often quoted and there are multiple amusing anecdotes attached to his name. For example, when Napoleon Bonaparte mentioned that God is not mentioned in the *Treatise*, Laplace replied “*Sire, je n'avais pas besoin de cette hypothèse.*” (“Sire, I had no need of that hypothesis.”) Laplace's

name is associated with one of the three fundamental partial differential equations,  $\frac{\partial^2 u}{\partial x^2} + \frac{\partial^2 u}{\partial y^2} = 0$  as well as an integral

transform which is used to solve initial value problems with piecewise-continuous functions. Laplace was often compared (unfavorably) with Lagrange. Laplace rarely gave proofs of his results and seemed uninterested in rigor while, Lagrange can be considered the first true analyst (Boyer).

**Adrien-Marie Legendre** (1752-1833)

Legendre was a contemporary of Laplace and Lagrange but is often not as well-known as these other two famous mathematicians. Legendre's name is most closely associated with the differential equation

$(1 - x^2)y'' - 2xy' + n(n + 1)y = 0$ , and particular the functions which satisfy this equation, which when  $n$  is a nonnegative integer are called Legendre polynomials. His *Éléments de géométrie* of 1794 was a significant pedagogical improvement of Euclid's *Elements*.

**Jakob Bernouilli** (1654-1705) and **Johann Bernouilli** (1667-1748) were two of the first adopters of the Leibnizian calculus and used it to solve important problems in the early 18<sup>th</sup> century. Jakob and Johann (sometimes called James and John) are the most famous brothers in the history of mathematics.

According to Boyer, the Jakob and Johann's father Nicolaus (1623-1708) had selected career paths for his son which did not include them being mathematicians. Jakob was supposed go into the ministry and Johann a merchant or physician.

**The First Calculus Text and “l’Hospital’s Rule”**

Perhaps because of this Johann made an unusual arrangement with **Marquis Guillaume François Antoine L’Hospital** (1661-1704) in which Johann would be paid a salary and in return send L’Hospital his mathematical discoveries.

L’Hospital published the very first textbook on differential calculus in Paris in 1696, called *Analyse des infiniment petits pour l’intelligence des Lignes courbes* (*Analysis of the Infinitely Small For The Understanding of Curves*) and in it he included a result of John Bernouilli's which has since then become incorrectly known as “L’Hospital’s Rule.”

$$\lim_{x \rightarrow a} \frac{f(x)}{g(x)} = \lim_{x \rightarrow a} \frac{f'(x)}{g'(x)}$$

**Maria Agnesi** (1718-1799)

The second most important European calculus text was published by Maria Agnesi in 1748 in Italian *Instituzioni analitiche ad usodella gioventu italiana* (*Foundations of Analysis for the Use of Italian Youth*) with a French edition in 1749. Agnesi is “the first important woman mathematician since Hypatia” (Struik). Unsurprisingly, Agnesi used Leibniz' notation, although the English translation in 1801(!) replaced all  $dx$ 's by  $\dot{x}$ 's (Katz 616).

**EXAMPLE**

There are three fundamental second-order partial differential equations (PDEs): elliptic, hyperbolic or parabolic. The general form of the general second-order PDE is of the form  $Au_{xx} + 2Bu_{xy} + Cu_{yy} + Du_x + Eu_y + Fu + G = 0$ . One can classify the three classic PDEs knowing the value of the discriminant  $D = B^2 - AC$ .

$D < 0$  means the PDE is elliptic,  $D > 0$  means the PDE is hyperbolic and  $D = 0$  means the PDE is parabolic.

There are three fundamental PDEs: Laplace's equation, the wave equation and the heat equation.

Let's match the fundamental PDE with its associated classification and value of  $D$ .

**British Calculus texts**

In England, mathematicians insisted on using the notation and monikers derived by Newton. **Thomas Simpson** (1710-1761) published *A New Treatise on Fluxions* in 1737 and **Colin Maclaurin** (1698-1746) published *a Treatise on Fluxions* in 1742.

**The Critic**

**George Berkeley** (1685-1743) was an Irish philosopher who printed a harsh criticism of Newton's calculus in 1734 which was titled (deep breath): *The Analyst, Or a Discourse to an Infidel Mathematician*. The subtitle was:

*Wherein It Is Examined Whether the Object, Principles, and Inferences of the Modern Analysis are More Distinctly Conceived, or More Evidently Deduced, than Religious Mysteries and Points of Faith. "First Cast the Beam Out of Thine Own Eye; And then Shalt Thou See Clearly to Cast Out the Mote of Thy Brother's Eye."*

Berkeley pointed out that Newton's fluxional calculus was useful at solving problems but said "by virtue of a twofold mistake you arrive, though not at science, yet at the truth" and scoffed at the notion of an instantaneous velocity which results from the quotient 0/0. The infidel mathematician in the title is widely believed to be Edmund Halley not Newton himself.

MacLaurin's text was an attempt to place the Calculus in a firmer context which he did by using more geometrically based techniques and he is widely considered the most talented British mathematician of the 18<sup>th</sup> century (Ball and Boyer).

MacLaurin is now best known for the Maclaurin Series where he assumes that a fluent  $y$  can be expressed as a power series in  $z$  where the coefficients will be fluxions.

$$y = E + \dot{E}z + \frac{\ddot{E}z^2}{1 \times 2} + \frac{\dddot{E}z^3}{1 \times 2 \times 3} + \dots$$

Even he noted that the result had been previously published in a work by **Brook Taylor** (1685-1731) in his *Methodus incrementorum (Method of Increments)* in 1715.

In modern notation, we designate a Maclaurin series (also known as a Taylor series about zero) as:

$$f(x) = f(0) + f'(0)x + \frac{1}{2}f''(0)x^2 + \frac{1}{6}f'''(0)x^3 + \dots$$

**Exercise**

Find the Maclaurin series for  $f(x) = \log(x+1)$

**Famous Curves**

Throughout the 18<sup>th</sup> century (and beyond) there was a popular (and sometimes lucrative) practice of challenging other mathematicians to find curves of certain kinds.

**The Catenary**

The shape of the curve of a flexible but inelastic cord hung between two points is known as **the catenary**. Jakob Bernouilli was unable to solve this problem but Huygens and Leibniz and (horrors!) his brother Johann were.

The solution in differential form for the catenary is

$$dx = \frac{ady}{\sqrt{y^2 - a^2}}$$

**Exercise**

Let's confirm that the closed form of the catenary is that  $x = a \ln(y + \sqrt{y^2 - a^2})$  or  $y = a \cosh(x/a)$

**The Witch of Agnesi (source: Wolfram'sMathWorld)**

The "witch of Agnesi" is a curve studied by Maria Agnesi in 1748 in her book *Istituzioni analitiche ad uso della gioventù italiana* (the first surviving mathematical work written by a woman). The curve is also known as cubique d'Agnesi or agnésienne, and had been studied earlier by Fermat and Guido Grandi in 1703.

The name "witch" derives from a mistranslation of the term *aversiera* ("versed sine curve," from the Latin *vertere*, "to turn") in the original work as *avversiera* ("witch" or "wife of the devil") in an 1801 translation of the work by Cambridge Lucasian Professor of Mathematics John Colson.

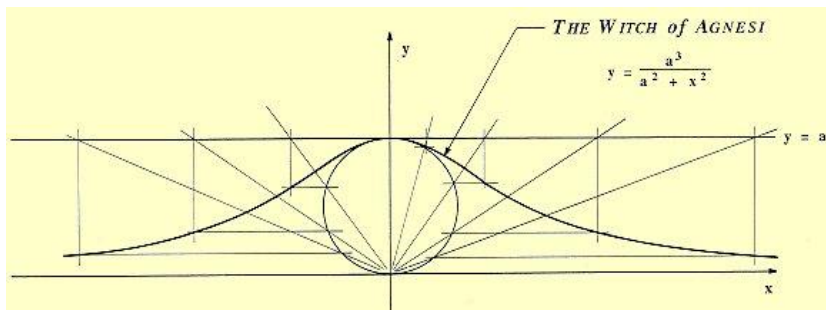
**Exercise**

Show that the curve depicted parametrically by  $x = 2at$ ,  $y = 2a/(1+t^2)$  is  $y = 8a^3/(4a^2 + x^2)$ , which is the closed-form equation for "the Witch of Agnesi"

**Legendre Polynomials**

Recall that Legendre Polynomials  $y(x)=P_n(x)$  satisfy the ODE  $(1-x^2)y''-2xy'+n(n+1)y=0$ .

The first few Legendre polynomials are  $P_0(x)=1$ ,  $P_1(x)=x$ ,  $P_2(x)=\frac{1}{2}(3x^2-1)$  with a general formula (due to Rodrigues') which states that

$$P_n(x) = \frac{1}{2^n n!} \frac{d^n}{dx^n} [(x^2 - 1)^n]$$

And a recursion formula (due to Bonnet) which is

$$(n+1)P_{n+1}(x) = (2n+1)xP_n(x) - nP_{n-1}(x)$$

Legendre polynomials have all sorts of very interesting properties. They form an orthogonal set with respect to the  $L^2$  norm on  $[-1,1]$ , which means that

$$\int_{-1}^1 P_n(x)P_m(x) dx = \begin{cases} 0, & \text{if } m \neq n \\ \frac{2}{2n+1}, & \text{if } m = n \end{cases}$$

**GROUPWORK**

Confirm that you can find  $P_2(x)$  using Rodrigues' and Bonnet's formula and show that it satisfies orthogonality with respect to the  $L^2$  norm on  $[-1,1]$ .